



Line-scan Applications Made Easy

Euresys Technical Note

INTRODUCTION

The development of line-scan applications is often perceived as much more complex than their area-scan counterpart. In this technical note, we will detail the functionalities offered by the Euresys frame grabbers that simplify the development and the setup of line-scan applications.

RATE CONVERTER

When developing a line-scan application, the usage of motion encoders is mandatory to achieve a constant aspect ratio of the acquired images. Obtaining the same resolution in the machine or transverse (lateral) directions, what is typically referred to as « square pixels », might however be difficult. Motion encoders featuring the required number of pulses per revolution are not always available.

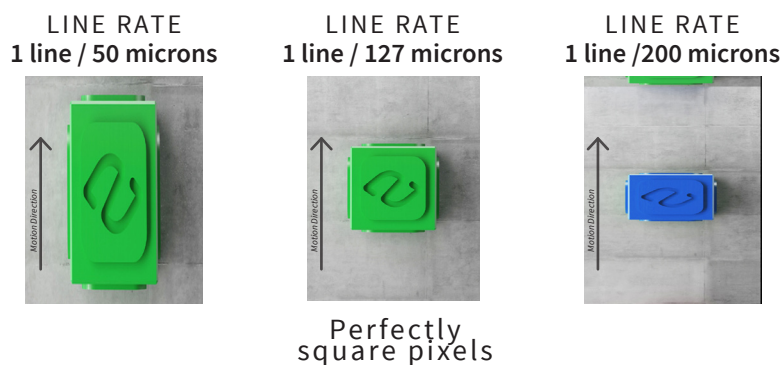

To achieve square pixels for any setup, Euresys provides a rate converter.

The rate converter is implemented in all Euresys' frame grabbers. The rate converter multiplies or divides the frequency of the signal issued by the motion encoder by any rational number. It, therefore, allows the camera to acquire lines at any programmable resolution, lower or higher than the resolution of the motion encoder.

If a line-scan application must evolve towards a higher resolution, it usually requires changing not only the camera or the CIS (Contact Imaging Sensor), but also the motion encoder. When using the rate converter, updating the multiplication/division factor allows to keep the same motion encoder while increasing the image resolution. This gives systems designers incredible freedom and flexibility during the development of a line-scan application.



BACKWARD MOTION CANCELLATION

Euresys' frame grabbers support quadrature motion encoders, i.e., they can decode A and B phases to know in which direction, forward or backward, a part is moving.

At low speed, when starting the motion, backward movements might be observed. Euresys' frame grabbers can be instructed to stop the line acquisition process once a backward motion is detected. The acquisition automatically resumes when the motion is, again, in the forward direction at the exact same place where the acquisition was interrupted.

DELAY TOOL

The trend in line-scan applications is to design systems as compact as possible. Due to the reduced available space, it is not always possible to place a sensor, such as a presence or proximity detector, at the same location as the line-scan camera.

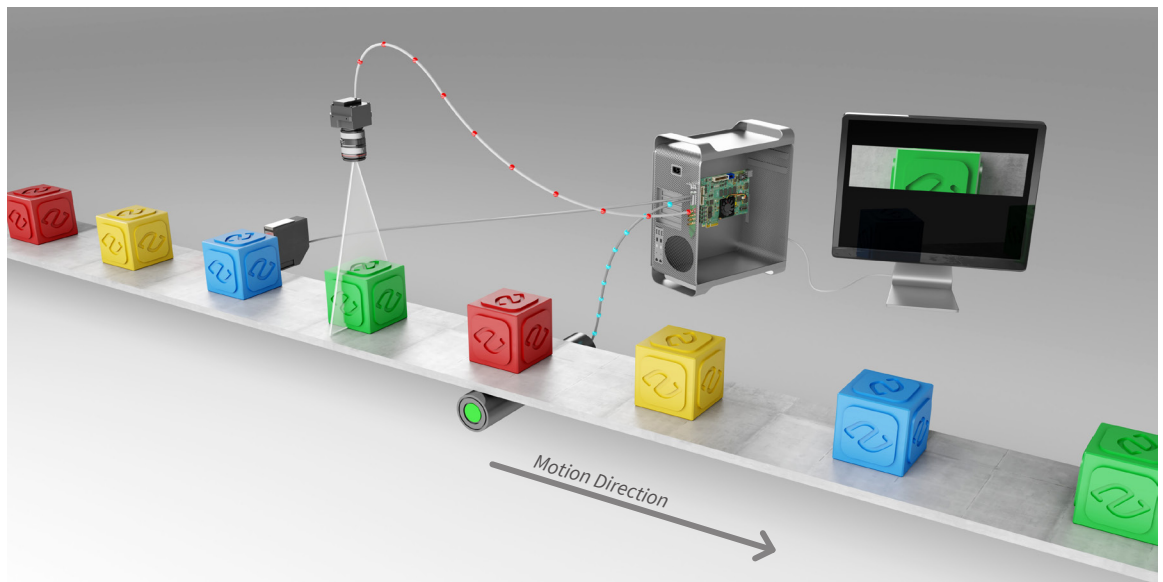

When inspecting discrete objects of finite size, presence detectors are usually used to start the scan. If a presence detector is located upstream compared to the camera, it is mandatory to postpone the start of the scan event until the object actually reaches the camera's field of view. To achieve this task, Euresys' frame grabbers are equipped with delay tools that introduce a delay between the object detection and the start of scan. This delay is expressed as a number of encoder ticks which ensures that any speed variation is taken into account.



C2C-LINK

Several cameras might be required to cover the whole area to be inspected. In this case it is mandatory to synchronize the acquisition for all these cameras. To achieve this task, Euresys frame grabbers support the so-called C2C-Link feature.

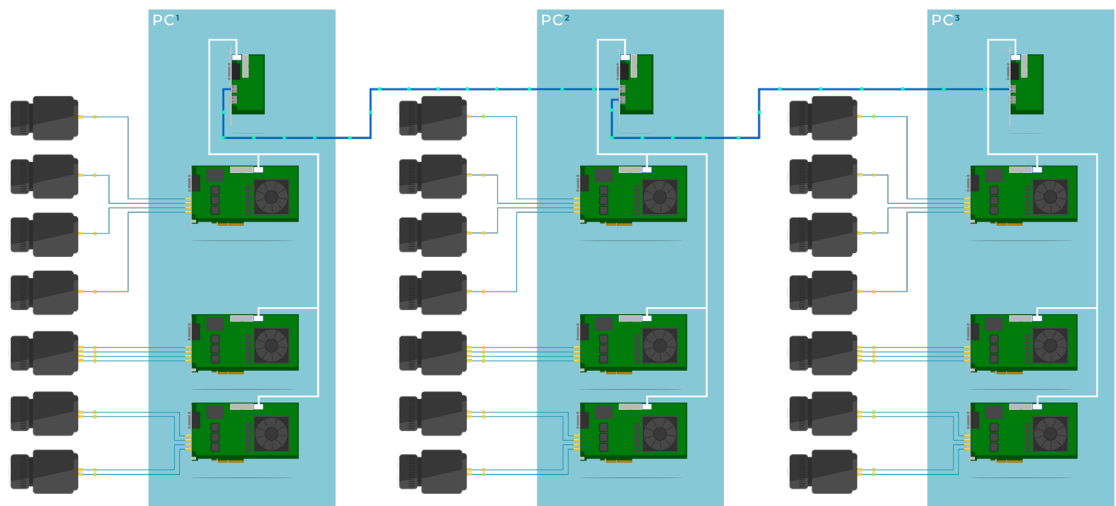

C2C-Link is able to accurately synchronize cameras that are connected to the same frame grabber, or to different frame grabbers in the same PC, or even to different frame grabbers in different PCs. The synchronization is managed through a master/slave architecture. The master board receives all trigger signals and propagates them to slave boards, ensuring that all cameras are acquiring lines at the exact same time.

USER ACTION SCHEDULER

Depending on the inspection result, the activation of external devices such as status lamps, cutters, ejectors, stampers... might be required. The synchronization of those devices with the image acquisition process is usually based on an encoder tick counter.

The User actions scheduler tool available on the Euresys' frame grabbers can generate user events or toggle the state of output lines. This allows the accurate scheduling of the operation of external devices connected to the frame grabber. The User actions scheduler can manage up to 64 actions at the same time .

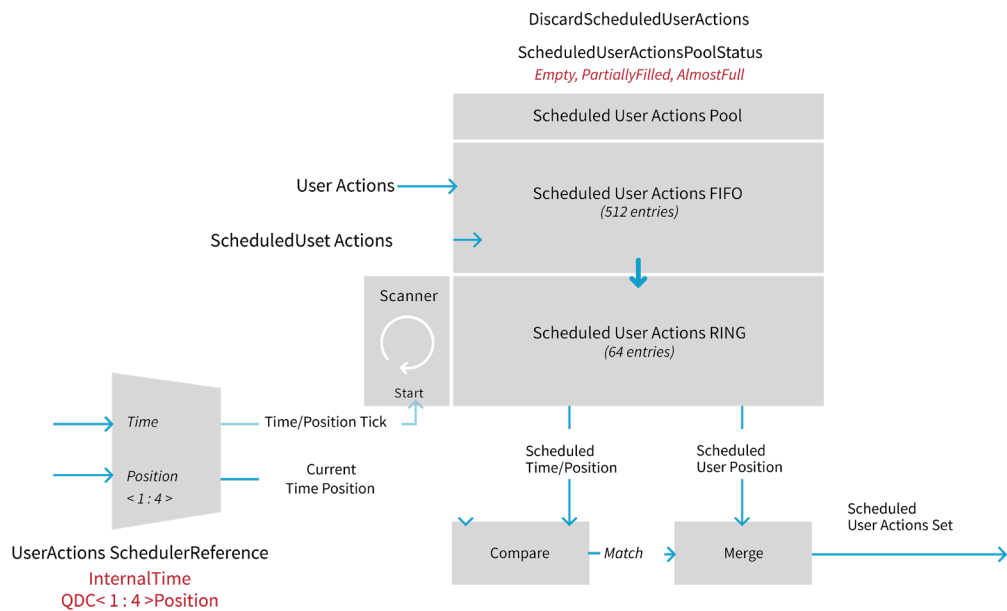

USERS ACTIONS SCHEDULER FUNCTIONAL DIAGRAM

METADATA

Basically, Metadata means additional bytes appended at the end of each image line. Metadata are used to report the frame grabber I/O state, the number of lines acquired so far, the encoder tick position, the value of a pulse or event counter... As such, they provide a snapshot of the system when a given line was acquired. The goal of the metadata is, for instance, to reconcile images acquired by different cameras located at distinct locations. Metadata are also especially useful to validate the behavior of a line-scan application. They allow to verify that a given line was acquired at the expected time. This is particularly important when the line-scan acquisition involves complex strobing sequences.

IMAGE STITCHING

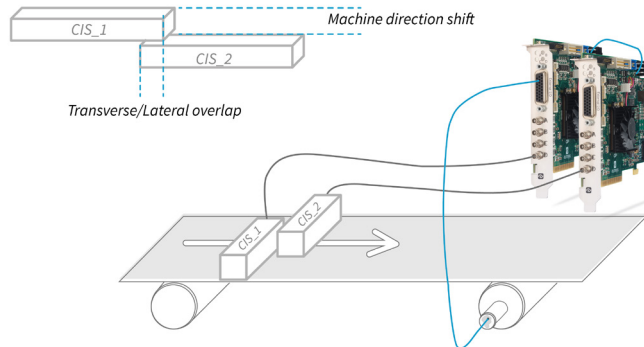

When several CIS are required to cover the whole area to be inspected, they are usually staggered. The reason is to avoid losing pixels between CIS that are placed side by side.

In this case, when stitching images, it is necessary to solve horizontal overlapping and Machine direction shift. Euresys' frame grabbers are DMA agents, i.e., the image stitching is performed on-the-fly by DMA transfer. It does not require any CPU usage, nor image copy.

Euresys frame grabbers support continuous web scanning to inspect infinite continuously moving surfaces without losing a single line as well as discrete object scanning, to acquire the image of objects moving in front of the camera

All features that, from design to implementation monitoring, allow the machine vision developer to use the same set of proven tools in various line-scan implementations.